

General Technical Specifications for Rubb Buildings and Shelters

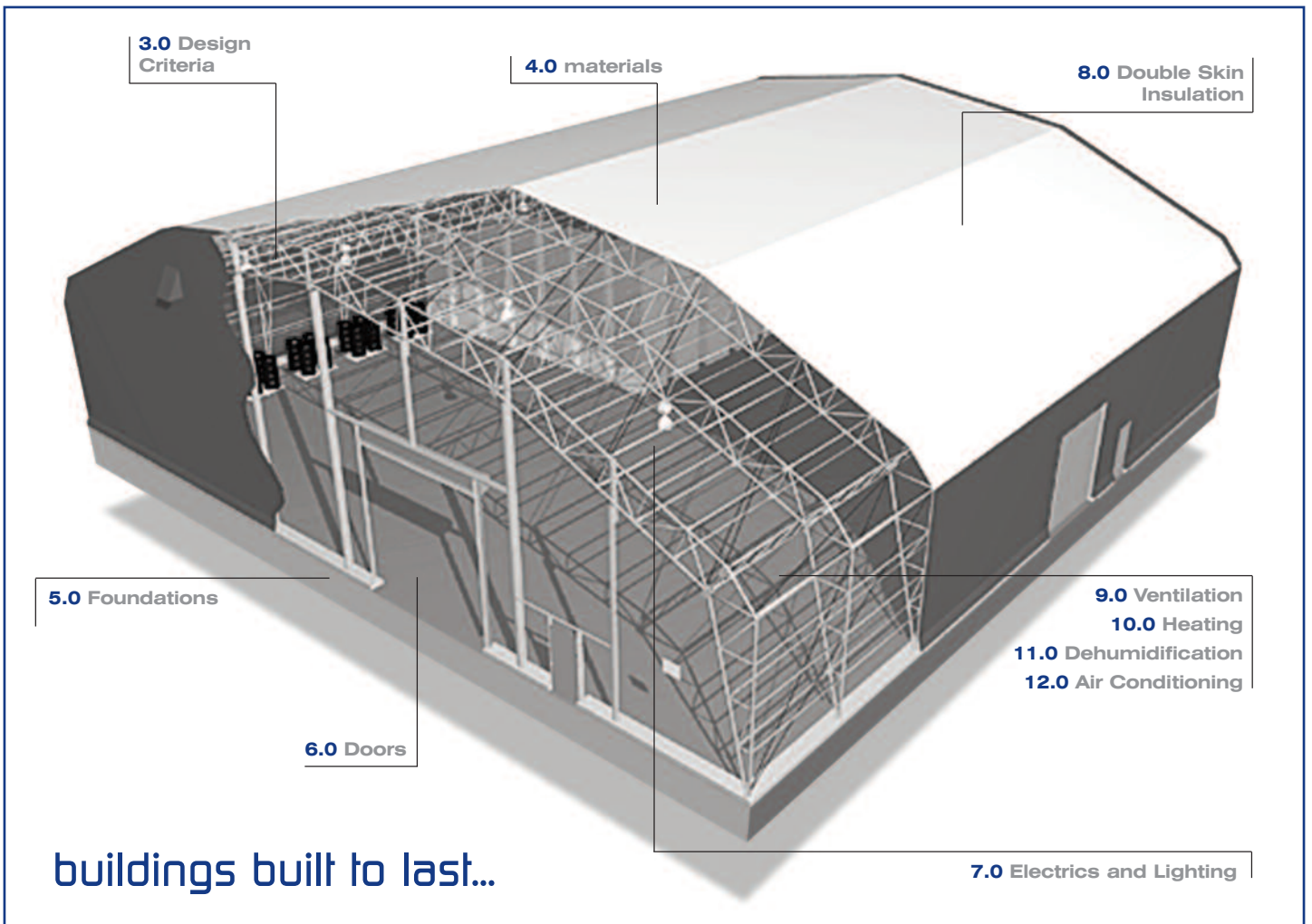



buildings built to last...

1.0 RUBB BUILDINGS LTD

Rubb Buildings Ltd has for over 30 years manufactured versatile, relocatable buildings for all types of applications throughout the world. Our buildings withstand climatic conditions ranging from the tropical to the Arctic. From the outset Rubb Buildings has maintained a strict quality policy encompassing design, materials, and the manufacturing process. We feel we can therefore say with confidence that, **“We make relocatable buildings built to last”**.

2.0 SERVICES

Our service does not end with the product itself. If required, we can handle any project on a ‘turn-key’ basis. We can provide all of the following services.

- Site surveys.
- Design of virtually any shape of building required.
- Design of foundations and floors.
- Applications for building regulation approval.
- Manufacture of buildings and shelters.
- Construction of foundations and floors.
- Electrical, heating, lighting, ventilation, dehumidification, air conditioning services etc.
- Transport.
- Erection.
- After sales service.

3.0 DESIGN CRITERIA FOR BUILDINGS

Rubb buildings are available in accordance with UK Building Codes with respect to wind and snow loads. They are designed in strict accordance with the following British standards and codes of practice:

BS 648:	Schedule of weights of building materials
BS 4360:	Weldable structural steels
BS 4848:	Hot rolled structural steel sections
BS 5950:	Structural use of steelwork in building.
BS EN 10219:	Cold formed welded structural sections.
BS 6399:	Part 1 - Code of practice for dead and imposed loads.
BS 6399:	Part 3 - Code of practice for imposed roof loads.

CP3 Chapter V Basic data for the design of buildings, Chapter V, loadings Part 2 - wind loads.

Rubb standard buildings are designed for a basic wind speed of 46m/sec (103mph), a 15 year category 3 exposure, and a basic snow load of 75kg/m². Most Rubb building ranges are also available to US BOCA code based on 35psf snow load and 90mph wind load. The buildings can be designed to a higher wind load (e.g. 120 mph) for customised projects. Higher snow load capacity can be achieved by reducing the modular distance between trusses.

4.0 MATERIALS

4.1 The steel structure: The hot-dipped galvanised steel structure of a Rubb building generally takes the form of a series of lattice tubular or box section steel frames at 3 to 7 metre centres. Tubular purlins span between each of the frames and provide the necessary support for the cladding. Each frame is composed of smaller more manageable sections, which bolt together on site. Buildings spanning up to 100m are available in any length. The hot-dip galvanised coating of all steelwork offers excellent corrosion protection with an estimated life in excess of 30 years. The high quality finish provides excellent resistance to transportation and erection damage.

Rubb also manufacture some structures in aluminium (e.g. RES Hangars).

4.2 The cladding: All buildings are clad with tough PVC impregnated polyester fabric. The sheets are sectioned in accordance with the length of the building and joined with special overlap joints. These joints are waterproof and able to withstand vibrations caused by high winds. The membrane is tensioned over the steel structure and anchored to the foundations. The quality fabric has a life expectancy of up to 25 years depending on environmental conditions. Moreover, due to ease of erection and attachment, the cladding can be replaced easily.

4.2.1 Fabric quality: Rubb buildings erected over 20 years ago still have their original cladding. The fabric has been tested with respect to tensile strength, elongation, tearing strength, bursting strength, coating adhesion and resistance to flexing according to BS 3424. The fabric is flame retardant and self-extinguishing to BS 5438 Test 2B (test certificates are available on request).

Rubb Quality 453 and 480 PVC impregnated Polyester Fabric

	453	480
Fabric:	Polyester	Polyester
Construction:	9 x 9/cm ² - plain	12 x 12/cm ² - 2/2
Dtex:	Weave 1100/1100	Panama 1100/1100
Total Weight:	Approx. 700g/m ²	Approx. 800g/m ²
Thickness:	Approx. 0.7mm	Approx. 0.8mm
Tensile Strength:	2200/2200/N/5cm	3000/3000/N/5cm
Tear Strength:	450/450N (Tongue Tear)	1000/800N (Tongue Tear)
Fire characteristics:	Self-extinguishing Flame retardant	Self-extinguishing Flame retardant

4.2.2. Fabric options: Colours

Virtually any colour is available on request, but our standard stock colours are:

- White translucent (usually used for roof sections for maximum natural daylight transmission)
- Blue
- Dark Brown (off white inside)
- Nato Green (off white inside)

UV stabilised

For hot, tropical climates we can offer fabric as above which is UV stabilised using an extra coating containing Titanium Dioxide pigment.

Camouflage / infra-red reflective

Membranes of PVC coated polyester fabric with external camouflage colouring and infra-red reflective material can be supplied.

NBC resistant

The structure can be supplied with an inner skin of polyethylene or polypropylene which can meet requirements of nuclear, bacteriological and chemical containment.

5.0 FOUNDATIONS

The preparation of a site for a Rubb building is usually the customer's responsibility. This would include site clearance and construction of the foundations. However, as previously mentioned, Rubb can act as the main contractor on any project.

Foundation requirements vary considerably depending upon the building size, intended period of exposure and on ground conditions. The smaller buildings may be fitted to a timber frame or a steel channel which can be bolted to a suitable existing concrete slab or anchored by ground anchors or other alternatives. The larger buildings can be bolted to a purpose made concrete ring beam or fitted to a steel beam which could be bolted to a suitable existing reinforced concrete slab.

The main frame of the building is designed for "pinned" base conditions. This results in relatively simple foundations, there being only nominal moments applied to the base. The buildings can be erected on an uneven surface or a sloping area and will accept high differential settlement of the foundations.

For a permanent solution, most customers provide a concrete slab with ring beam on which to secure the building. A concrete upstand can be either monolithic with foundation beams, or cast on top of an existing slab. Composite action in the latter case may be achieved by drilling the existing slab and grouting in reinforcing bars around which the concrete forming the new upstand can be poured.

5.1 Buildings on wheels: Rubb buildings can be fitted with wheels using a continuous steel foundation. The larger structures are fitted with wheels and run on rails. Smaller shelters can be fitted with rubber tyred wheels.

5.2 Lifting a building: When a building is to be lifted, a continuous steel foundation along the length of the structure is essential. This can be an angle or U-channel for small units or I- beams for larger structures. Buildings can be lifted using the correct sling arrangement and lifting beam. Normally, 4 modules can be lifted using a 6 legged sling without the need for a lifting beam.

FOUNDATION ALTERNATIVES

ALTERNATIVE 1

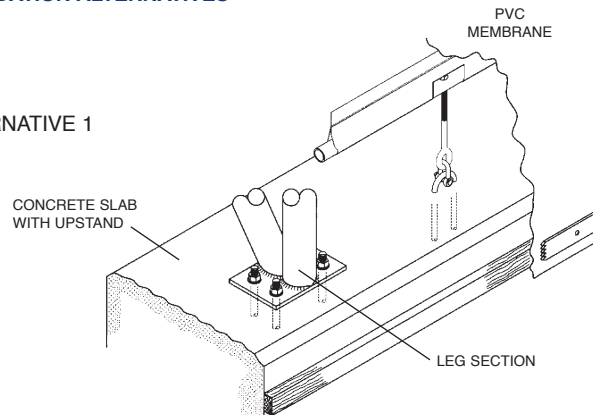

ALTERNATIVE 2

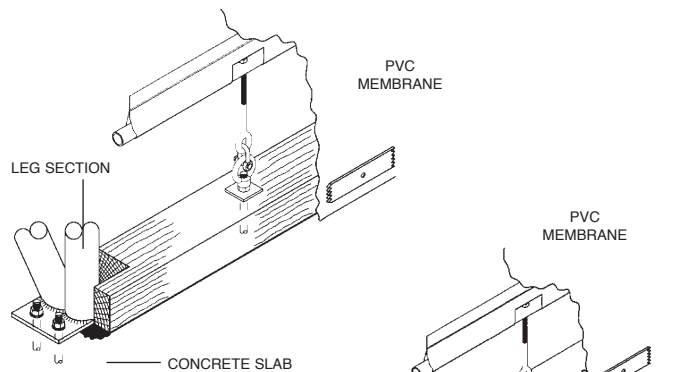

ALTERNATIVE 3

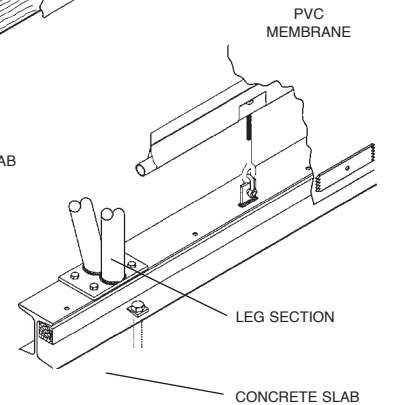

6.0 DOORS

Rubb buildings can be fitted with any door arrangement. Large doors are preferably located in the gable ends. Doors up to 4.6m width (depending on building configuration) can be fitted in the side of a building as standard. For customised projects larger doors in the side are possible (see brochure).

Our standard doors are as follows:

- Access door (standard 0.8m wide x 2.0m high)
- Roller shutter doors (up to 7.0m wide x 5.0m high)
- PVC folding doors (up to 5.5m wide x 4.4m high)
- Sliding aircraft doors (up to 20m wide x 6.0m high)
- Folding aircraft doors (up to 18m wide x 7.0m high)

We can however, supply any door configuration required, building size permitting. We have supplied doors over 70m wide and up to 12m high.

7.0 ELECTRICS AND LIGHTING

The white translucent roof provides a good level of natural light during day-light hours. However, we can design and install complete lighting and electrical requirements to suit the activity within the building. All types and standards of light fittings and installations are available ranging from the Fluorescent Batten, Hi-bay or Lo-bay type to the special purpose flame-proof and water-proof fittings. Our buildings can also be installed with emergency lighting to BS 5266 and Fire Alarms to BS 5839. The complete installation will be carried out in strict accordance with the current I.E.E. Regulations. Kit form lighting can be provided for connecting to generators. All fittings can be attached to, or suspended from the building structure. Savings on lighting costs due to the translucent roof membrane are substantial.

8.0 DOUBLE SKIN INSULATION

Heat loss can be reduced in our buildings by the provision of an inner skin attached to the inner structure. By adding an insulating material between the two skins, it can be made to comply to the latest British Standards Building Regulations. Various types of insulating material which can be used to suit individual requirements / preferences include, standard glass fibre and Rockwool.

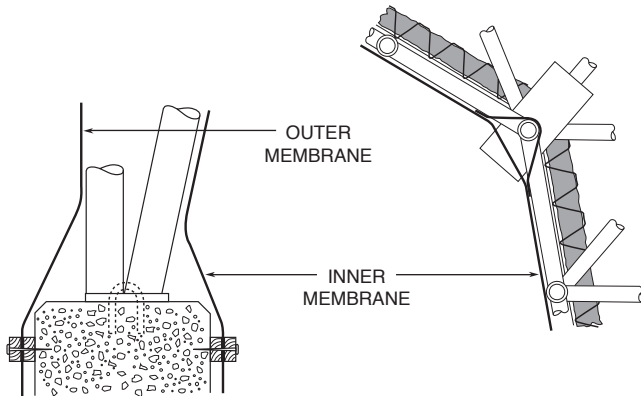

9.0 VENTILATION

Ventilation is required to:

- Avoid condensation
- Maintain air quality
- Avoid unpleasant heat exposure

As standard, the Rubb building is supplied with vent openings in the gables to allow some natural ventilation. Other openings can be positioned in the side walls to provide a higher level of natural ventilation. These openings can be fitted with ventilation fans to provide the recommended number of air changes per hour, to suit the activity within the building. Special ventilation i.e. paint spray, fumes, soot and exhaust extraction can also be accommodated within our services.

10.0 HEATING

As part of the service we also undertake a comprehensive heating installation designed to comply with individual requirements and locations. We can utilise existing sources on site, i.e. gas, steam, LPG, oil, electric etc. We can also undertake the supply and installation of oil storage tanks. Heating units including the re-circulation type can be located either inside or outside the building and supplied with various types of ductwork to provide the correct environmental conditions for the activity within the building.

Where air movement is not considered desirable - e.g. Sports Halls, radiant systems utilising gas or electricity can be installed.

11.0 DEHUMIDIFICATION

It is commonly held that a store must be heated to prevent moisture problems. This is not the case and savings of up to 75% can be made using dehumidification as compared to heating. Due to the fact that Rubb structures are covered in an air tight fabric they are ideal for dehumidified storage. A ground sheet can easily be welded to the side walls to prevent rising damp from any existing floor slab. Rubb can supply complete dehumidified storage systems for use in existing warehouses and other buildings. These may consist of total structures, custom fit bags or drop shrouds.

12.0 AIR CONDITIONING

Air conditioning can be provided for the whole or specific areas within the building to suit the clients requirements. In general, all other pipe services, e.g. compressed air, water, gas or oil can be installed.

13.0 AIRTIGHT AND LIGHT INHIBITING STRUCTURES

Rubb has extensive experience in designing, manufacturing and erecting structures which are required to be virtually airtight and at the same time must inhibit light ingress. Such structures are of particular use in the water treatment sector where air tightness prevents unpleasant odour escape, and algae growth is inhibited by providing light-proof conditions.

14.0 STANDARD PROFILES OF RUBB BUILDINGS *all dimensions in metres*

NV RANGE OF BUILDINGS With 3 m. sidewalls. Alternative sidewalls optional.

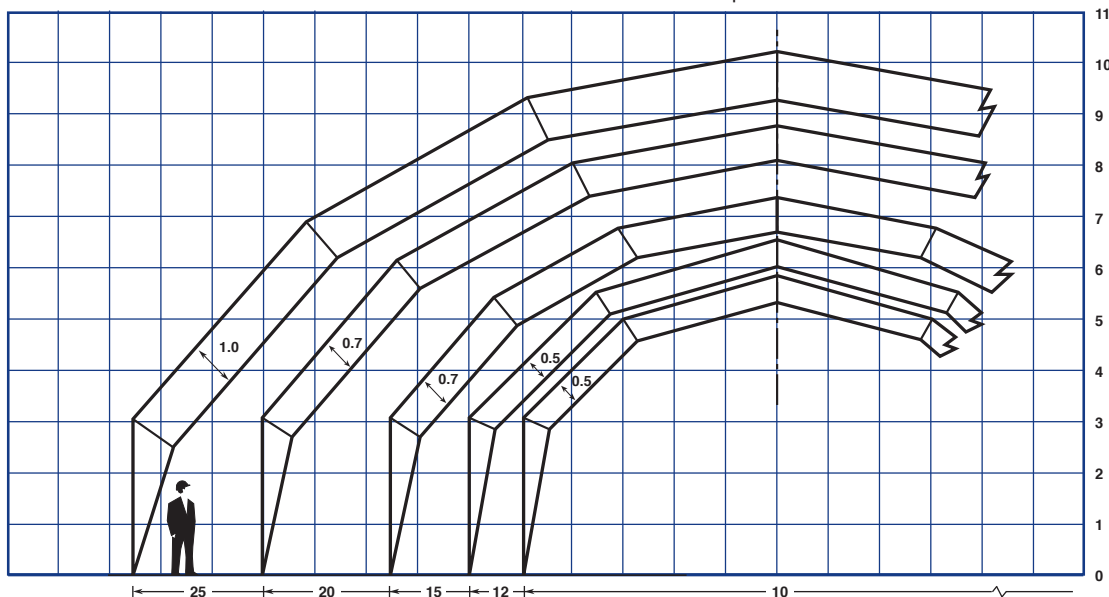

BVR RANGE OF BUILDINGS Special purpose Rapid Erection structures and Sunshades.

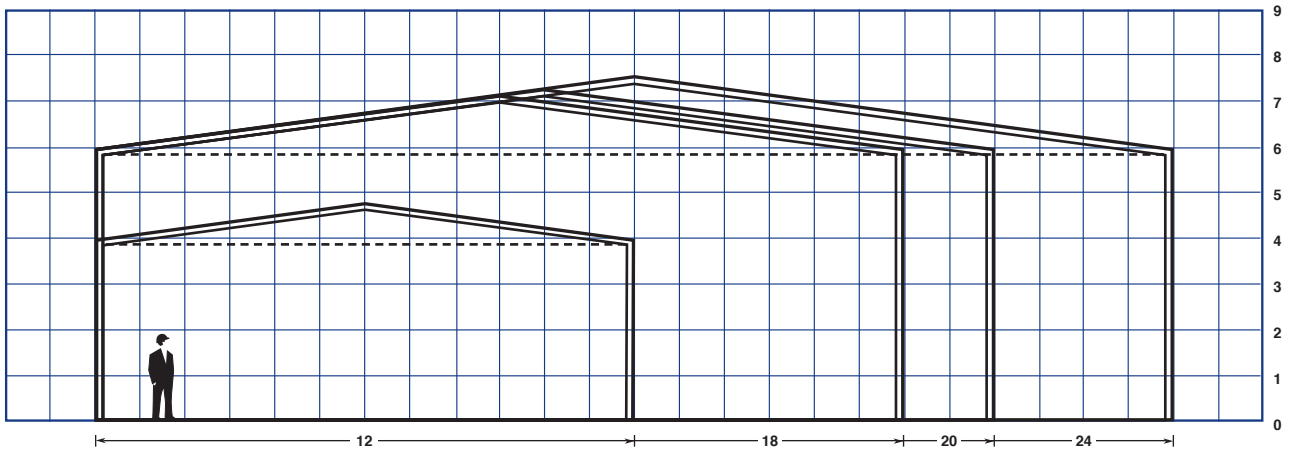

BVE RANGE OF BUILDINGS Available in single span configurations, alternative sidewalls optional.

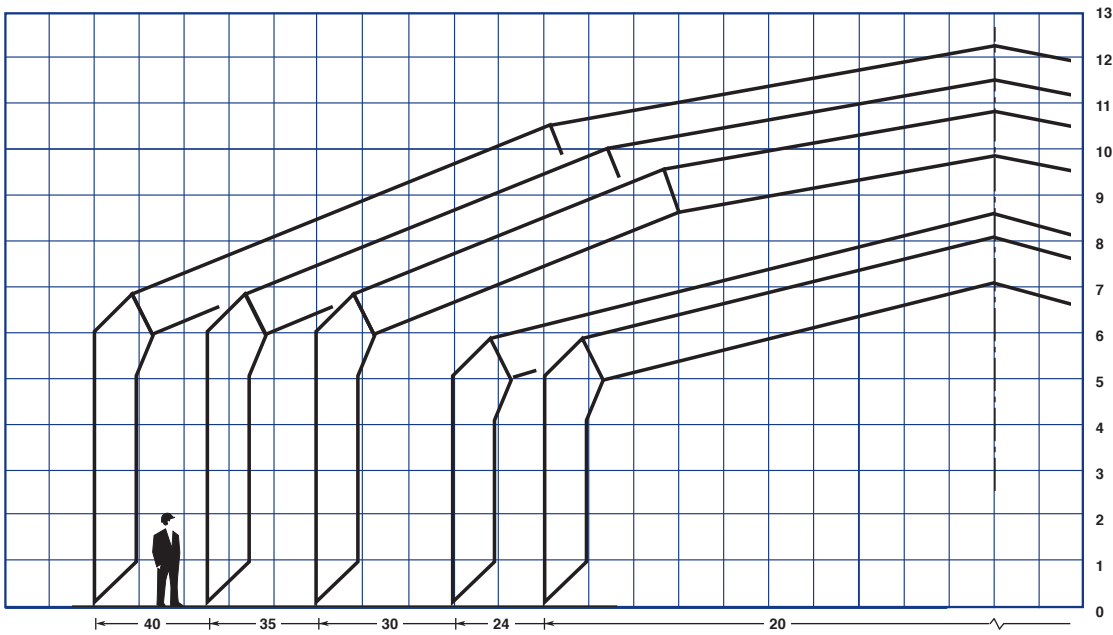

BVE RANGE OF BUILDINGS - LINKSPANS Also 24m, 30m and 35m spans available.

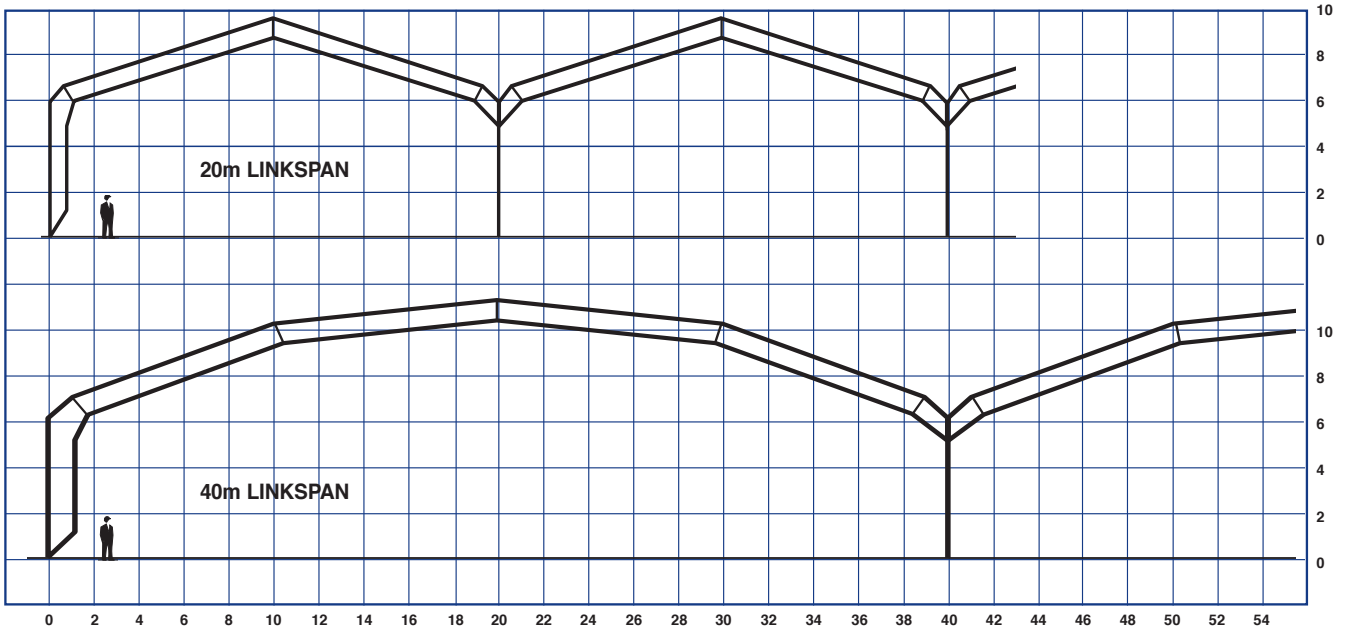

BVL RANGE OF BUILDINGS With spans up to 100m and sidewalls up to 25m. adjusted to customer requirements.

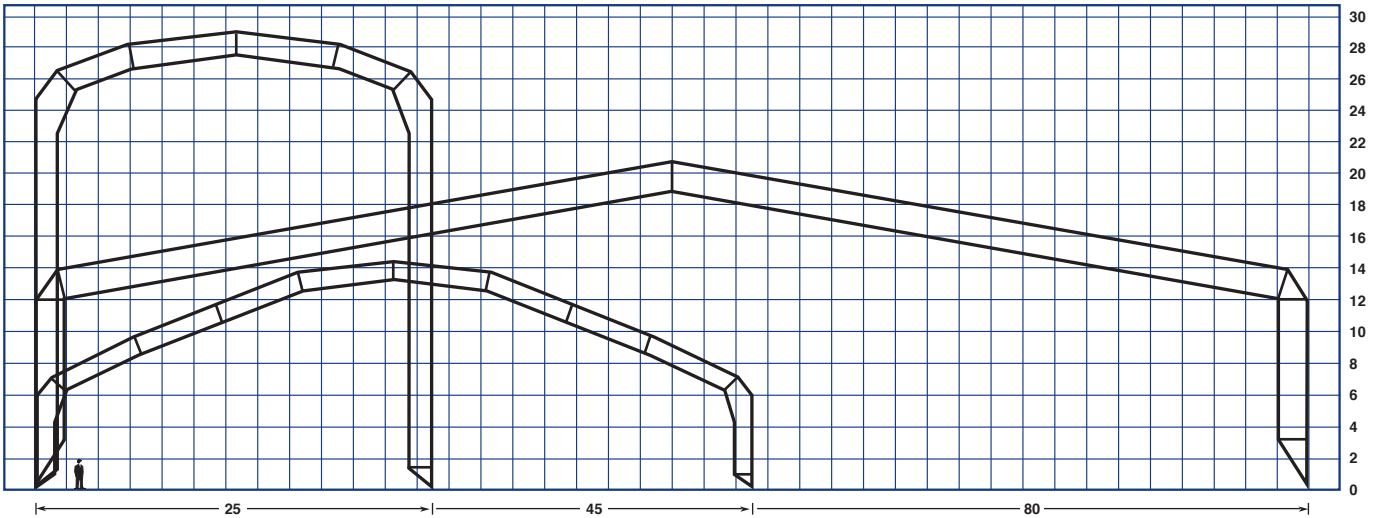

RES RANGE OF BUILDINGS With spans up to 25m and sidewalls up to 5.5m

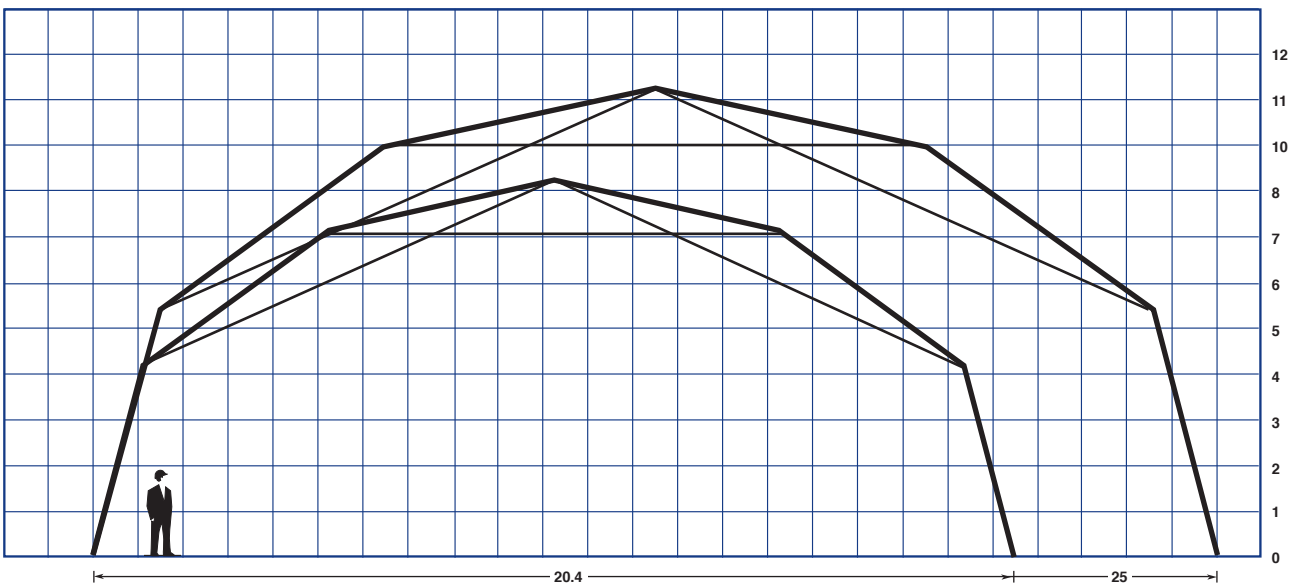

15.0 TH SHELTER RANGE

Rubb shelters have a similar specification to buildings, but because they are designed for more temporary usage they do not conform to UK Building Regulations for wind and snow loads. Rubb manufacture standard shelter kits in the THA, THB and TH ranges as shown in the tables. Any length can be supplied in 3m long modules for all shelter designs. Models THA, THB have vented gable ends which are welded to the first roof section for extra rigidity. All shelters are easy to erect by unskilled labour with no special tool requirements. A typical kit comprises, steel frame, all fixings, PVC coated 453 polyester fabric, integral steel ringbeam, vent duct, single or double lace up or folding door and erection documentation. Framework is hot-dipped galvanised tubular steel. Joint design is mostly spring clip style with few loose bolts. The fabric membrane is self-extinguishing.

3. Kit for lifting
4. Ground sheet
5. All white fabric tropical quality
6. Lighting kit
7. Wheel system
8. Clear windows
9. Customers' company logo/name on shelter
10. Complete erection and supervision
11. Ventilation fan
12. Ventilation ducts (incl. as standard on THA and THB in each gable)
13. Steel clad walls

16.0 OPTIONAL EQUIPMENT/SERVICES

1. Door Alternatives

- a. Rubb PVC folding door (incl. as standard on THA and THB).
- b. Steel roller shutter door.
- c. Lace up doors (incl. as standard on TH).
- d. Personnel doors.

2. Foundation Alternatives

- a. Ground anchor kit for virgin land with steel spikes.
- b. Ballast weight kit (ballast not included).
- c. Expansion bolt kit for fastening to concrete.
- d. Bolts for resin anchoring (hard core/asphalt).
- e. Steel foundation, hot dip galvanised (incl. as standard on THA and THB).

17.0 WEIGHTS AND DIMENSIONS *standard shelters*

TH RANGE

Dimensions (w x l) (m)	3 x 6	4 x 6	5.5 x 6	7 x 6
Weight including cover (kg)	410	425	446	469
Weight of each 3m ext. (kg)	146	155	165	176
Standard door opening (w x h) (m)	Single lace-up	2 x 2	2.5 x 2	3 x 2.5

THA RANGE

Dimensions (w x l) (m)	6 x 6	8 x 9	10 x 9	12 x 9
Weight including cover (kg)	1099	1652	1881	2269
Weight of each 3m ext. (kg)	281	321	351	434
Standard door opening (w x h) (m)	3.3 x 3.3	3.5 x 3.8	4.5 x 4.1	5.5 x 4.4
Volume/in m ³ per m ² floor area	3.87	4.17	4.47	4.75
Snow loading capacity (kg/m ²)	109	95	45	55

THB RANGE

Dimensions (w x l) (m)	7 x 9	9.75 x 9	13 x 9	-
Weight including cover (kg)	1451	1757	2205	-
Weight of each 3m ext. (kg)	269	325	429	-
Standard door opening (w x h) (m)	3.0 x 2.7	4.5 x 3.1	6.0 x 3.5	-
Volume/in m ³ per m ² floor area	3.11	3.51	3.95	-

FOUNDATION ALTERNATIVES

TH RANGE: With the TH, no foundation frame is included. A foot plate is welded to the bottom of the leg section. This can be bolted to a wood foundation with coach screws or on to a steel channel foundation shown in figs 1. and 2.

THA AND THB RANGE: With these shelters a continuous steel angle foundation is included. Alternative foundation arrangements are shown in figs. 3, 4 and 5.

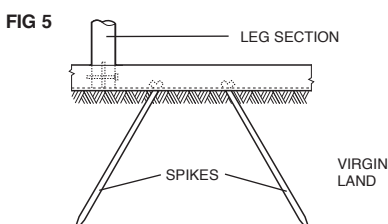
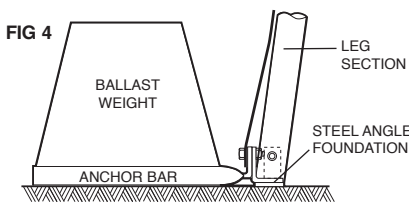
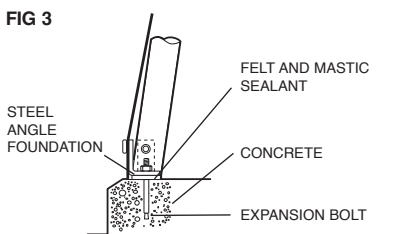
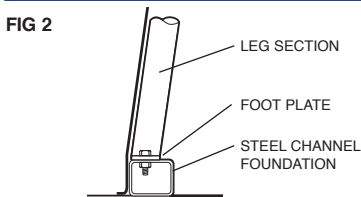
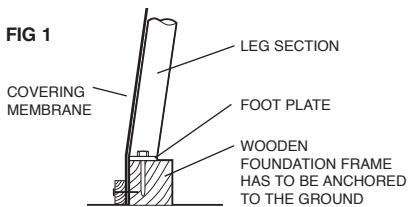

N.B. Shelters to be lifted or fitted with wheels require a steel foundation frame.

IMPORTANT: The user is responsible for securing the structure to the ground. Depending on ground conditions, anchor hooks may not be sufficient. Any additional anchoring down arrangements to secure the structure are the users responsibility

THA RANGE OF SHELTERS

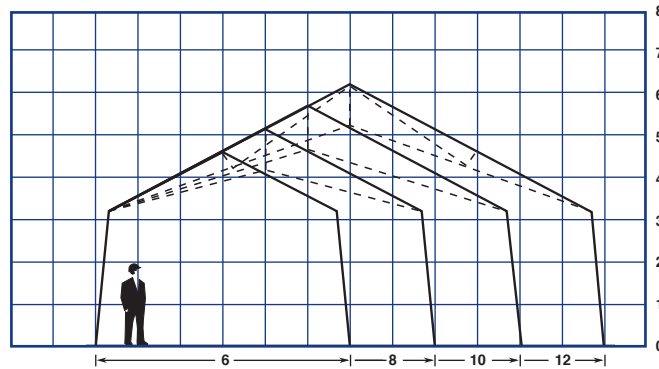

THB RANGE OF SHELTERS

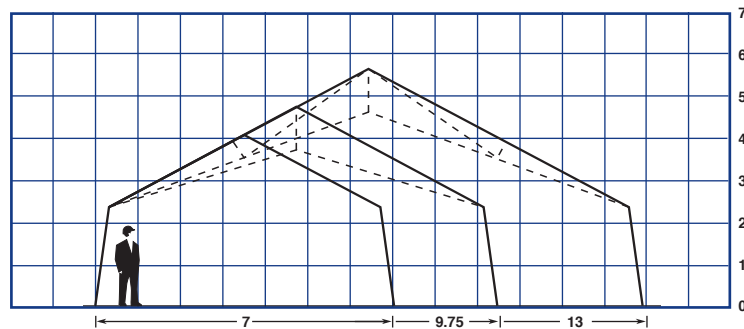

CVB RANGE OF SHELTERS

Designed to be mounted directly on a standard ISO container

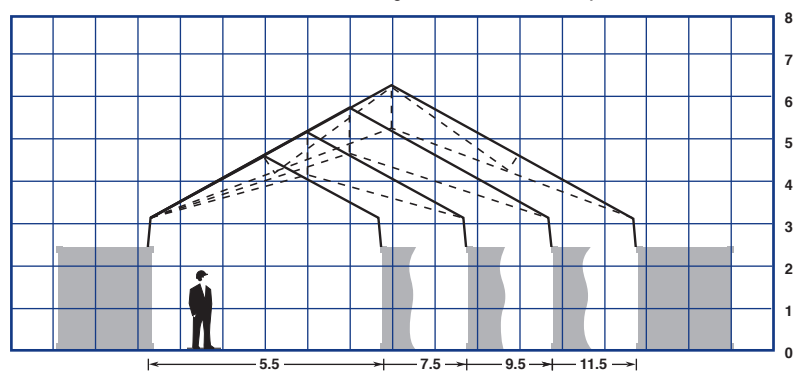

CXB RANGE OF SHELTERS

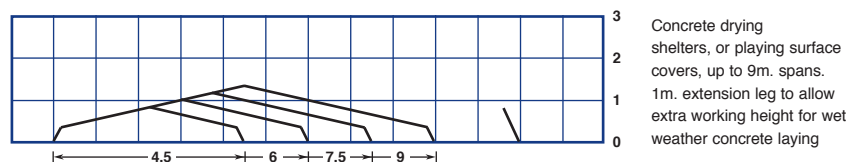

TH RANGE OF SHELTERS

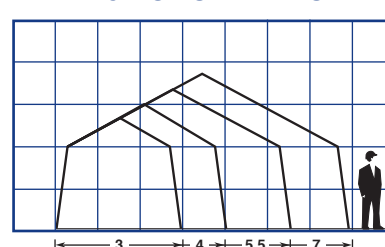

RDS RANGE OF SHELTERS

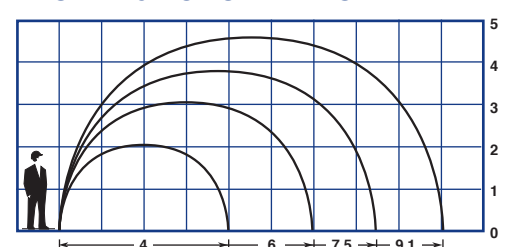

18.0 CUSTOM DESIGNED STRUCTURES *all dimensions in metres*

Rubb understands that not all our customers requirements fit our standard building solutions. We have therefore built up a competent engineering team that can make exactly what a customer demands. We have as a result of this made a wide variety of 'non-standard' buildings. These vary from very high side wall structures (up to 23m to date), to circular structures, to lean-to with internal cranes, to water tank covers. We are willing to consider any task that encompasses our technical know how in order to satisfy customer requirements.



BVL RANGE Adapted for soccer application at Newcastle United FC.

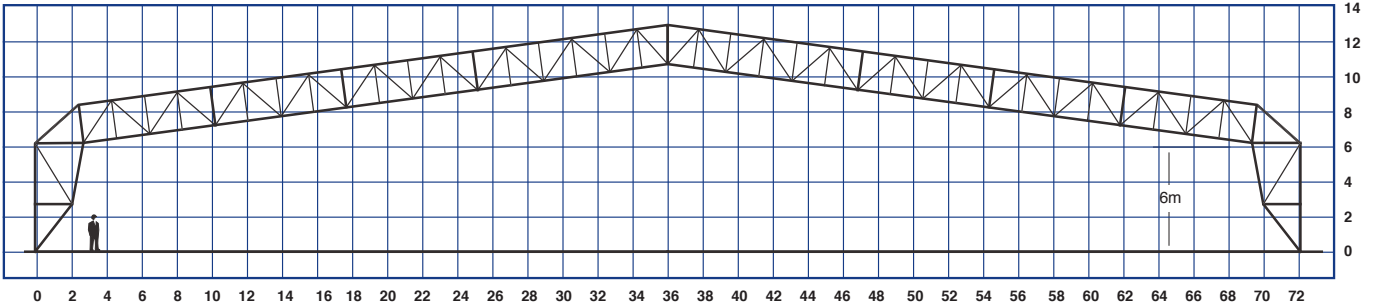

BVE RANGE Adapted for tennis application.

The tennis market requires very specific envelopes specified by the LTA. Rubb has therefore designed a variation of the BVE to comply exactly with these LTA specifications. The structure has also been adapted to look more architectural than a standard Rubb building.

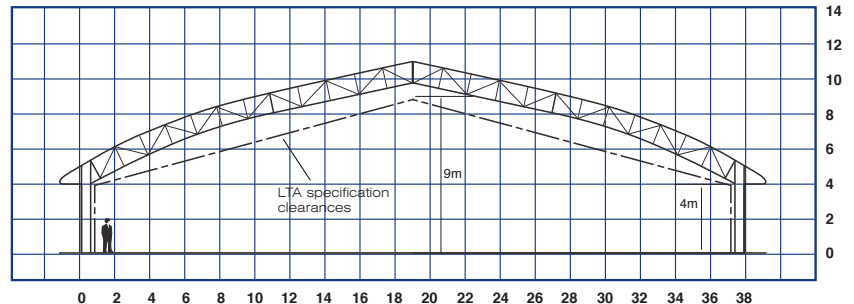

19.0 SHIPPING

Rubb buildings and Shelters, being of modular construction can be crated, strapped in bundles suitable for handling by crane or truck, or packed into standard ISO containers for shipping by sea, air, rail or road.



In the interests of product development Rubb reserve the right to alter specifications without prior notice. The information provide here is for guidance only and does not form any part of contractual offer.

20.0 ERECTION

Rubb buildings and Shelters are designed to be speedily erected with minimum equipment. Buildings can be erected using customers' own labour (we can assist by providing an erection supervisor on an hourly basis), or by a Rubb erection team at a fully inclusive price. Rubb have extensive experience in this field and can offer this service anywhere in the world, improvising with minimum equipment where necessary.

21.0 QUALITY ASSURANCE

Rubb designs, manufactures and erects structures which conform fully with ISO 9001 Quality Assurance standards. Rubb also meet the requirements of Nato and US military codes of conformity. Leading insurance underwriters have, after exhaustive testing, approved Rubb buildings, from a fire safety aspect, for housing £57.5m aircraft.



RUBB POLAND Sp. z o.o. ul. Starowiejska 232/234
08-110 Siedlce/Poland. Tel: +48 25 632 77 88. Fax: +48 25 632 88 99
Email: biuro@rubb.pl www.rubb.pl
Oddział Zachód - Jeszkowice. Tel: +48 71 329 70 13 rubb@rubb.pl
Oddział Północ - Gdańsk. Tel: +48 58 554 77 88 info@rubb.pl